

**Date**

2010

**Client**

London Council

**Status**

Competition Entry

**Awards**

**Description**

The idea for this landmark is to be at once, a gateway, a tower, a wayfinder, a pointer, a place, a landmark and yet potentially invisible. The structure will appear dynamic through the faceted surfaces from which light will be reflected throughout the day. At night these surfaces will be illuminated by the building or street lamps. The “spire” will contribute its own light as will the illumination from the inner surfaces.

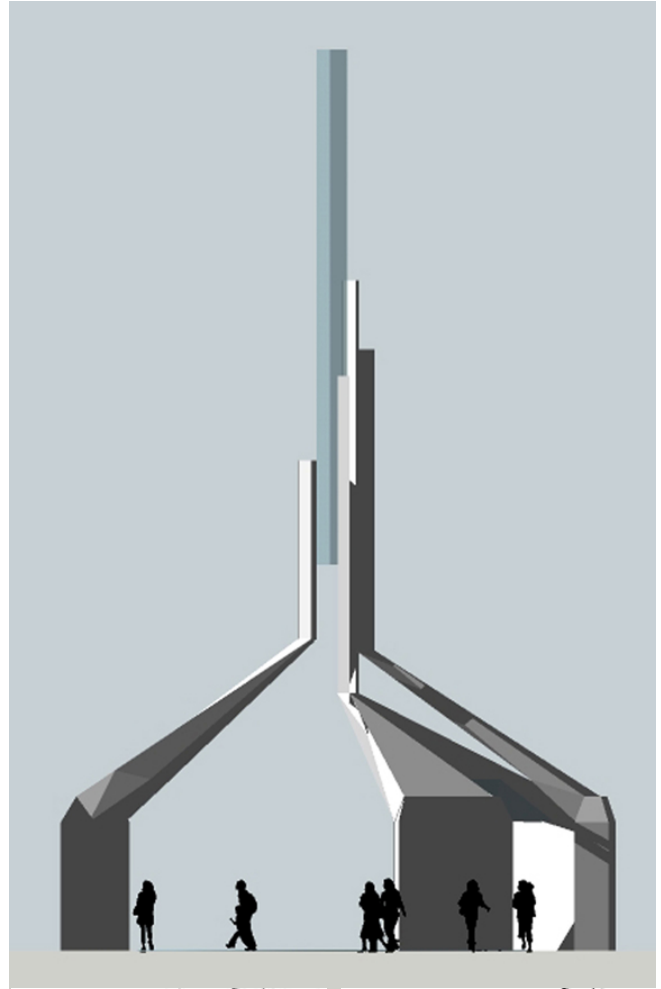

**Condition**

The existing island formed from the residue of numerous interventions.

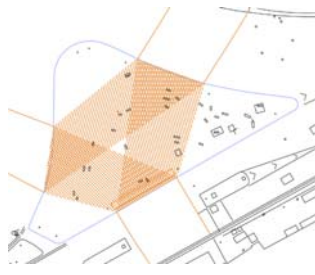

**Path - Movement**

The path is the only fluid aspect flowing over the myriad services.



**Centre Paving**

The centre (still point) is marked and remembered with an engraved stone dias with engraved historical facts related to Aldgate



**Strategic Placement**

The structure proposed nestles between the limits of movement and infrastructure. A gate, a tower, a marker, a place, everything to everyone.

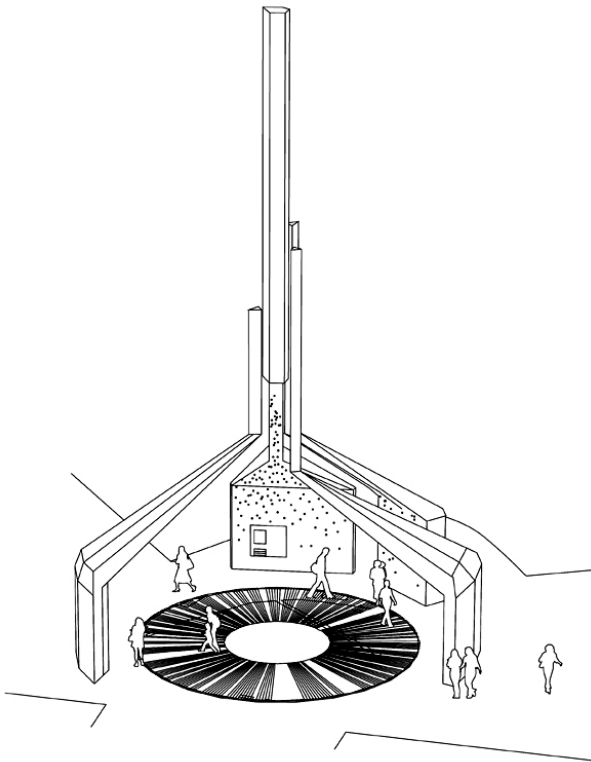

In addition to its strategic positioning to avoid both infrastructure and the path of people we are suggesting the inclusion of an ATM styled stamping machine from which visitors to Aldgate could have their postcards franked with a specially designed logo for the structure and in commemoration of the Olympic Games 2012.

The structure is to be manufactured offsite in 5 components, 4 legs and 1 spire. The loading pads onto which the steel "legs" are fastened are positioned to avoid underground services. When located the legs provide the table support for the spire. This is reversed when the structure is moved to a different site. Only the paving at the centre will remain as a memory to the event.